

CAD FILE:

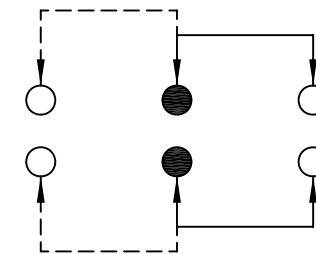

SCHEMATIC (NON-SHORTING)

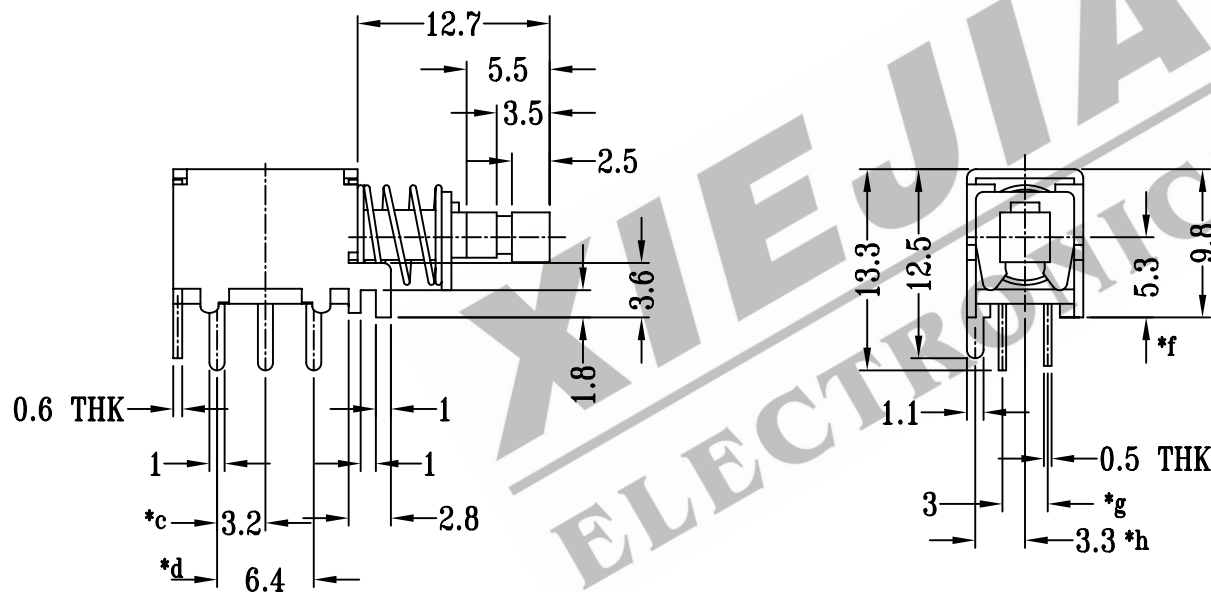
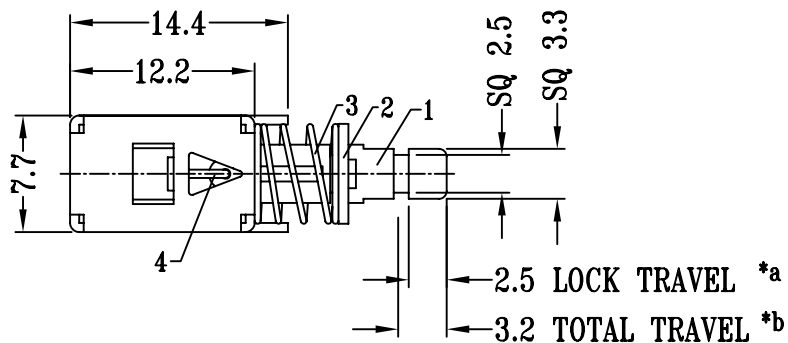
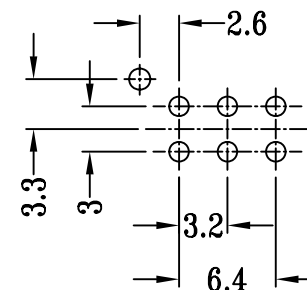

P.C.B LAYOUT

注:带"*"表示关键尺寸(8个)

9	CONTACT CLIP	PBS STRIP	2	Ag PLATED	TOLERANCE UNLESS SPECIFIED	SHENZHEN XIEJIA ELECTRONICS CO.,LTD.				
8	TERMINAL	BRASS STRIP	6	Ag PLATED OVER Ni PLATED						
7	BASE	PHENOLIC RESIN	1	NATURAL	WITHIN: 1.5±0.1mm OVER: 1.5±0.2mm	ISSUE	DATE	DESCRIPTIONS OF REVISION		APPD.
6	FRAME	STEEL STRIP	1	Ni PLATED		TITLE : PUSH SWITCH				
5	SPRING PLATE	PBS STRIP	1	NATURAL	UNIT : mm					
4	LOCK NEEDLE	PBS WIRE	1	NATURAL	MODEL: PS-22F31 (LOCKED)					
3	SPRING	STEEL WIRE	1	Ni PLATED	SCALE: 2 : 1					
2	BLOCK	STEEL STRIP	1	Ni PLATED	DWN. ZHOUYU 2003-11-3					
1	KNOB	POM	1	BLACK	CHK'D FANGYING 2003-11-3					
NO.	PARTS	MATERIALS	Q'TY	FINISH	APPD. KANGXINAN 2003-11-3					
					ALL MATERIALS MUST BE COMPLIANT TO ROHS					